

● Ball screw specifications

Shaft diameter (mm) - Lead (mm)	15 - 10		
Number of circuits / Thread direction	1.5 turns 1 circuit / Right-hand		
Ball diameter (mm)	3.175		
Root diameter (mm)	12.5		
Series	GG	GE	
Basic dynamic load rating C (N)	4400		
Basic static load rating C0 (N)	7900		
Accuracy grade / Axial clearance symbol	C5 / S	C5 / F	C7 / M
Axial clearance (mm)	0	0.005 or less	0.030 or less
Preload torque (N·cm)	1.0 to 8.0	Up to 3.0	----
Spacer ball	None		
Recirculation system	Tube method		
Wiper	Lip seal		
Lubricant	Alvania Grease S2		

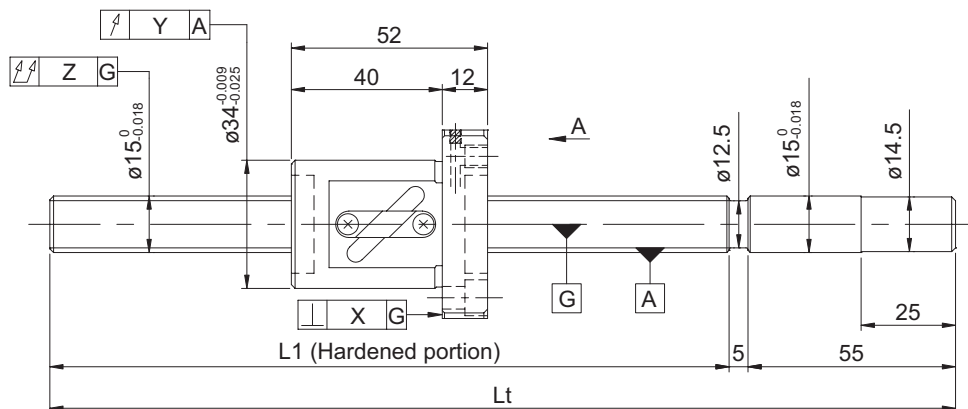
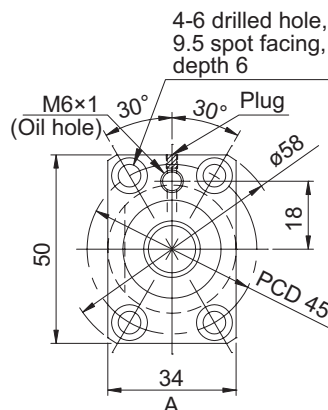

Model No. (Unfinished shaft ends)	Screw shaft length		Maximum stroke (L1 - nut length)	Lead accuracy		
	L1	Lt		$\pm E_c$	$e_c$	$e_{300}$
GG1510AS-BALR-0600A	540	600	488	0.030	0.023	0.018
GG1510AS-BALR-0900A	840	900	788	0.040	0.027	
GG1510AS-BALR-1100A	1040	1100	988	0.046	0.030	
GE1510AS-BALR-0600A	540	600	488	0.05/300	----	----
GE1510AS-BALR-0900A	840	900	788			
GE1510AS-BALR-1100A	1040	1100	988			

- Product with axial clearance of 0.005 or less (F) shown may be partially preloaded.
- Preload torque is a value before applying grease.

● Shaft end finish type

Standard precision ball screws are available with KURODA's recommended shaft end finish types for each size.

Other than KURODA's recommended shaft end finish types described below, additional machining including keyways, tapped holes, and D-cut processing are also available if requested. Please contact KURODA with your orders. Model examples for finished shaft ends are described below.

**Model example:** Unfinished shaft ends (See left figure) → Finished shaft ends  
GG1510AS-BALR-1100A → GG1510AS-BALR-1100X1028-C5F  
↳ Overall screw shaft length  
↳ Thread length

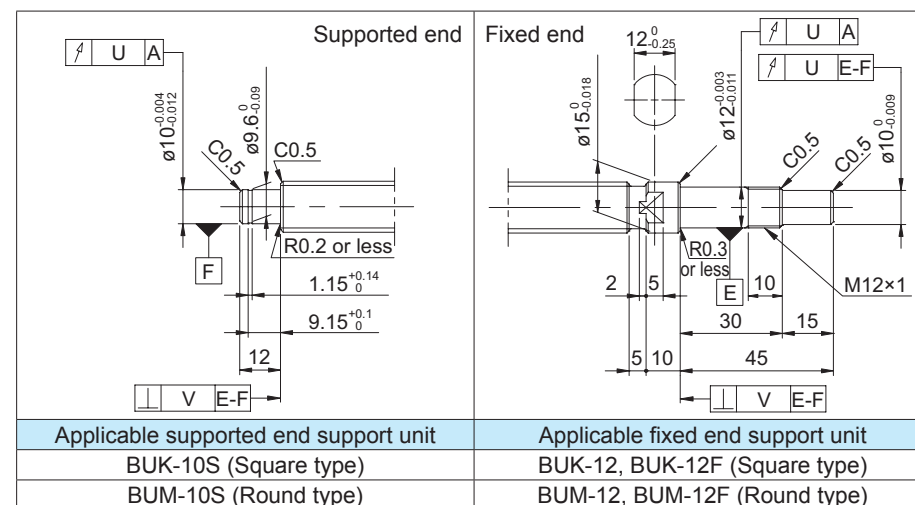

● Optional specifications

- Ball screw lubricating unit LUBSEAL can be equipped.  
**Model example:** GG1510AS-BASR-1100X1028-C5F  
↳ Wiper material S: LUBSEAL
- Anticorrosive black coating (coating thickness: 1 to 2  $\mu\text{m}$ ) is available.

Accuracy of each part					Preload torque (N·cm)		Mass (kg)
X	Y	Z	U	V	Without clearance	With clearance	
0.011	0.015	0.075	0.012	0.005	1.0 to 7.0	Up to 3.0	1.09
		0.120					1.47
		0.150					1.72
0.018	0.030	0.110	----	----	----	----	1.09
		0.170					1.47
		0.210					1.72

- At the time of delivery, grease is inserted inside of the nut, with rust-preventive oil also applied. Before and during use, apply lubricant where appropriate.
- For models with lead accuracy grade of C3 or higher and unfinished shaft ends, consult KURODA.