

● Ball screw specifications

Shaft diameter (mm) - Lead (mm)	12 - 4		
Number of circuits / Thread direction	2.5 turns 1 circuit / Right-hand		
Ball diameter (mm)	2.3812		
Root diameter (mm)	10.1		
Series	GG	GE	
Basic dynamic load rating C (N)	3600		
Basic static load rating C0 (N)	6750		
Accuracy grade / Axial clearance symbol	C5 / S	C5 / F	C7 / M
Axial clearance (mm)	0	0.005 or less	0.030 or less
Preload torque (N·cm)	0.2 to 4.7	Up to 1.0	----
Spacer ball	None		
Recirculation system	Tube method		
Wiper	Lip seal		
Lubricant	Alvania Grease S2		

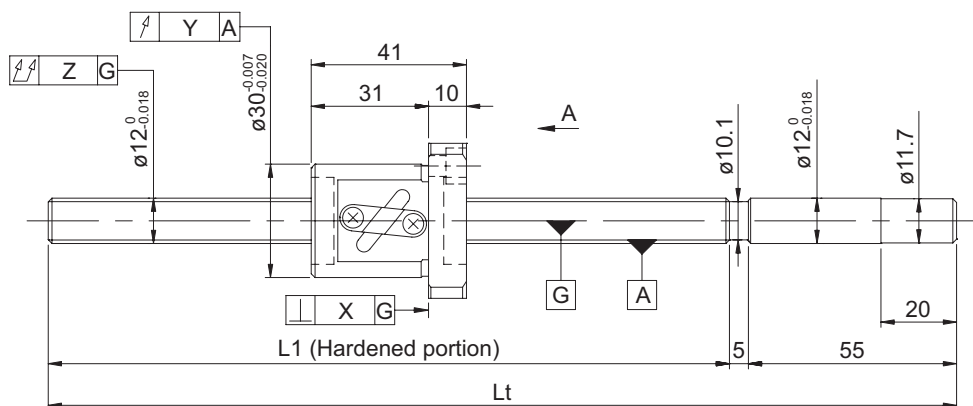
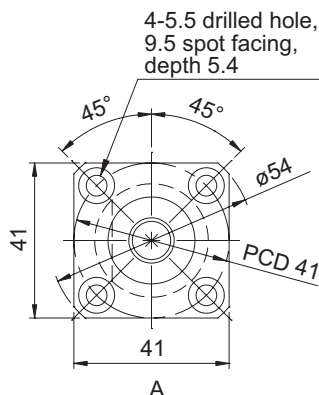

Model No. (Unfinished shaft ends)	Screw shaft length		Maximum stroke (L1 - nut length)	Lead accuracy		
	L1	Lt		$\pm E_c$	e_c	e_{300}
GG1204DS-AALR-0405A	345	405	304	0.025	0.020	0.018
GG1204DS-AALR-0605A	545	605	504	0.030	0.023	
GE1204DS-AALR-0405A	345	405	304	0.05/300	----	----
GE1204DS-AALR-0605A	545	605	504			

- Product with axial clearance of 0.005 or less (F) shown may be partially preloaded.
- Preload torque is a value before applying grease.

● Shaft end finish type

Standard precision ball screws are available with KURODA's recommended shaft end finish types for each size.

Other than KURODA's recommended shaft end finish types described below, additional machining including keyways, tapped holes, and D-cut processing are also available if requested. Please contact KURODA with your orders. Model examples for finished shaft ends are described below.

Model example: Unfinished shaft ends (See left figure) → Finished shaft ends
 GG1204DS-AALR-0605A → GG1204DS-AALR-0605X0535-C5F
 ↳ Thread length
 ↳ Overall screw shaft length

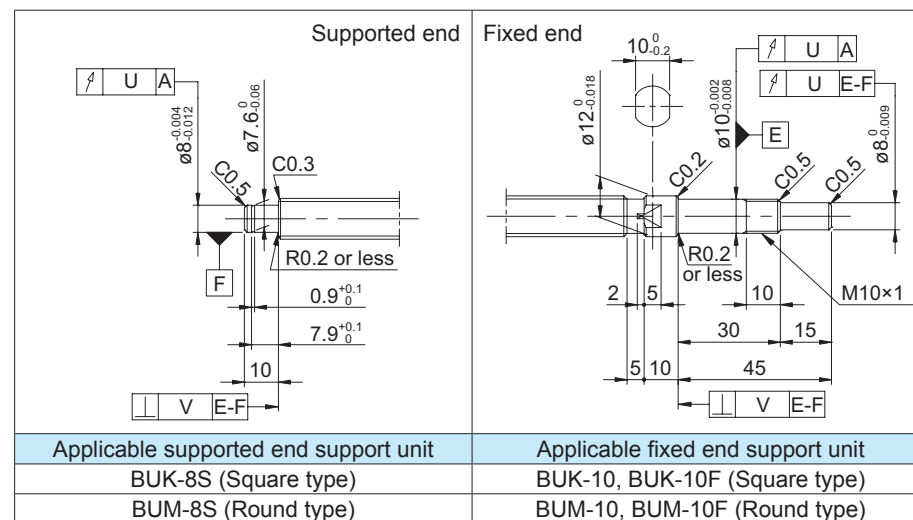

● Optional specifications

- Anticorrosive black coating (coating thickness: 1 to 2 μm) is available.

Accuracy of each part					Preload torque (N·cm)		Mass (kg)
X	Y	Z	U	V	Without clearance	With clearance	
0.010	0.012	0.080	0.011	0.005	0.2 to 4.7	Up to 1.0	0.56
		0.090					0.70
0.014	0.020	0.120	----	----	----	----	0.56
		0.150					0.70

- At the time of delivery, grease is inserted inside of the nut, with rust-preventive oil also applied. Before and during use, apply lubricant where appropriate.
- For models with lead accuracy grade of C3 or higher and unfinished shaft ends, consult KURODA.