

# Support units

BUKE (square type), BUK (square type), BUM (round type), BUT (round type)

## Features

- **Support units suited to various mounting configurations are available for your selection**
  - The support unit types include square types (BUKE series, BUK series) and round types (BUM series, BUT series). They can be selected according to mounting configuration requirements.
- **Providing bearings optimized for ball screws**
  - BUKE series (Square type) adopts radial ball bearings with the accuracy grade of P0. They are best suited for accuracy grade C7 or C10 ball screws in light load, conveyance applications.
  - BUK series (square type) and BUM series (round type) employ a DF type combined angular contact ball bearings with an accuracy grade of P5 and a contact angle of 30°.
  - BBUT series (round type) employs a DF type high-thrust angular contact ball bearings with an accuracy grade of P4 and a contact angle of 60°.
- **Built-in locking function**
  - By employing a lock nut made specifically for bearings with a built-in locking function, optimal perpendicularity in assembly can be achieved.

### □ Notation of the model number of the support unit

Example model number	Type	Inner diameter of bearing (mm)	Combination
	BUK		15
Square type : BUKE		Inner diameter of fixed end bearing 6, 8, 10, 12	F: Fixed end unit
Square type : BUK		Inner diameter of fixed end bearing 6, 8, 10, 12, 15, 20, 25	F: Fixed end unit S: Supported end unit
Round type : BUM		Inner diameter of supported end bearing 6, 8, 10, 15, 20, 25	A (set): F + S (*Set only for BUK) No mark: F + Support bearing
Round type : BUT		Inner diameter of fixed end bearing 20, 25, 30, 35, 40	* For BUT, only the fixed end unit is available.

### □ Table of ball screw compatibility

Model number	Inner diameter of fixed end bearing (mm)	Inner diameter of supported end bearing (mm)	Applicable series						
			FE/FG	DP	HG	GP	GE/GG	GW	GY
BUK BUM	6	6	-	0601	0606	-	-	0802	08□
BUK BUM	8	6	-	08□ 1002	0812	08□ 10□	08□ 10□* 12□	10□	10□
BUK BUM	10	8	1010 12□*	12□	1230	12□	1010 12□*	12□	12□
BUK BUM	12	10	15□	1404	15□ 1632	15□	15□ 16□	15□ 1632	15□ 1632
BUK BUM	15	15	20□	-	20□	20□	20□ 2040	20□ 2040	20□ 2040
BUK BUM	20	20	25□	-	2550	-	25□	25□	25□ 2806
BUK BUM	25	25	-	-	3264	-	32□	-	32□
BUT	30	-	-	-	-	-	-	-	36□
BUT	35	-	-	-	-	-	-	-	40□

### □ Main parts and materials

Square type: BUKE series

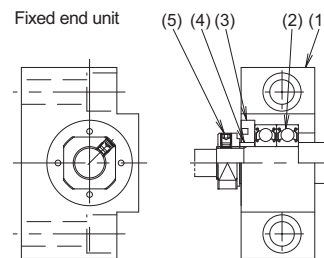

BUKE series Fixed end unit Main parts and materials

No.	Description	Material	Q'ty	Remark
1	Bearing housing	Structural steel	1	Blackening
2	Radial bearing		1 set	
3	Cover flange	Structural steel	1	Blackening
4	Spacer	Structural steel	1	Blackening
5	Lock nut (with a set piece)	Structural steel (brass set piece)	1	Blackening

- When the above parts are used in combination with a rolled ball screw, a collar (Material: structural steel, blackening) is required.
- Because the radial bearing is suitably preloaded during assembly, do not disassemble Part Numbers 1, 2, and 3.

Square type: BUK series

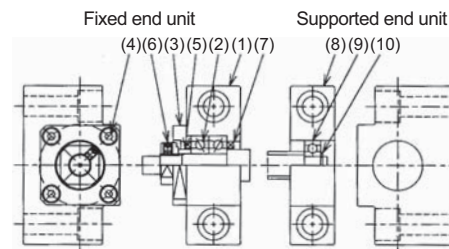

BUK/BUM series Fixed end unit Main parts and materials

No.	Description	Material	Q'ty	Remark
1	Bearing housing	Structural steel	1	Blackening
2	Bearing		1 set	
3	Cover flange	Structural steel	1	Blackening
4	Head cap screw with hexagonal socket		4	
5	Spacer	Structural steel	1	Blackening
6	Lock nut (with a set piece)	Structural steel (brass set piece)	1	Blackening
7	Oil seal	Synthetic rubber	2	

- When the above parts are used in combination with a rolled ball screw, a collar (Material: structural steel, blackening) is required.
- Round type: For BUM (fixed end unit), no blackening treatment is applied on the housing and the mounting surface of the outer face.
- To maintain appropriate preload do not disassemble Part Numbers 1, 2, 3, and 7.

Round type: BUM series

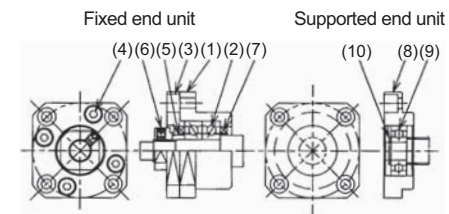

BUK/BUM series Supported end unit Main parts and materials

No.	Description	Material	Q'ty	Remark
8	Bearing housing	Structural steel	1	Blackening
9	Bearing		1	
10	Clip washer		1	

Round type: BUT series

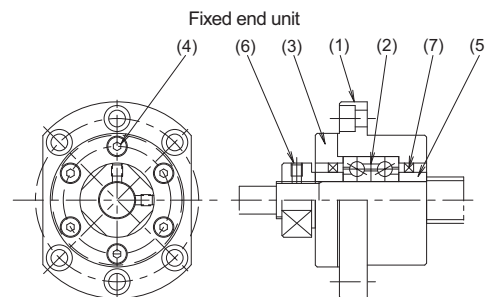

BUT series Fixed end unit Main parts and materials

No.	Description	Material	Q'ty	Remark
1	Bearing housing	Structural steel	1	Anticorrosive black coating
2	Bearing		1 set	
3	Cover flange	Structural steel	1	Anticorrosive black coating
4	Head cap screw with hexagonal socket		6 or 8	
5	Spacer	Structural steel	2	Anticorrosive black coating
6	Lock nut (with a set piece)	Structural steel (brass set piece)	1	Anticorrosive black coating
7	Oil seal	Synthetic rubber	2	

- Round type: For BUT (fixed end unit), no anticorrosive black coating is applied on the housing and the mounting surface of the outer face.
- To maintain appropriate preload do not disassemble Part Numbers 1, 2 and 3.

□ Bearing data

● BUK/BUM series Fixed end bearing (Combined angular contact ball bearing)

Model No. of support unit	Model No. of bearing	Axial force			Maximum starting torque (N·cm)
		Basic dynamic load rating (N)	Preload (N)	Rigidity (N/μm)	
BUK-6, BUM-6	706ADFP5	2670	30	38	0.5
BUK-8, BUM-8	708ADFP5	4400	49	52	0.8
BUK-10, BUM-10	7000ADFP5	6170	120	95	2
BUK-12, BUM-12	7001ADFP5	6770	140	100	2.2
BUK-15, BUM-15	7002ADFP5	7740	170	120	2.3
BUK-20, BUM-20	7204ADFP5	18200	350	193	5.5
BUK-25, BUM-25	7205ADFP5	20600	500	230	7.5

● BUK/BUM series Supported end bearing (Deep groove ball bearing)

Model No. of support unit	Model No. of bearing	Basic dynamic load rating (N)
BUK-6S	606ZZ	1720
BUK-8S, BUM-8S	608ZZ	2620
BUK-10S, BUM-10S	6000ZZ	3600
BUK-15S, BUM-15S	6002ZZ	4400
BUK-20S, BUM-20S	6204ZZ	10100
BUK-25S	6205ZZ	11000

● BUT series Fixed end bearing (High-thrust angular contact ball bearing)

Model No. of support unit	Model No. of bearing Inner diameter × Outer diameter × Width/Combination/ Accuracy symbol (Width when combined)	Axial force			Maximum starting torque (N·cm)
		Basic dynamic load rating (N)	Critical load (N)	Rigidity (N/μm)	
BUT-20	20×47×30-DFP4	25900	32000	735	10
BUT-25	25×62×30-DFP4	29900	46400	981	15
BUT-30	30×62×30-DFP4	29900	46400	981	15
BUT-35	35×72×30-DFP4	32500	54300	1230	20
BUT-40	40×72×30-DFP4	32500	54300	1230	20

\* Model No. of bearing: Inner diameter × Outer diameter × Width/Combination/Accuracy symbol (Width when combined)

● BUKE series Fixed end bearing

Model No. of support unit	Model No. of bearing	Maximum starting torque (N·cm)
BUKE-6	606	2.5
BUKE-8	608	2.5
BUKE-10	6000	2.5
BUKE-12	6001	2.5

□ Recommended screw shaft end dimensions

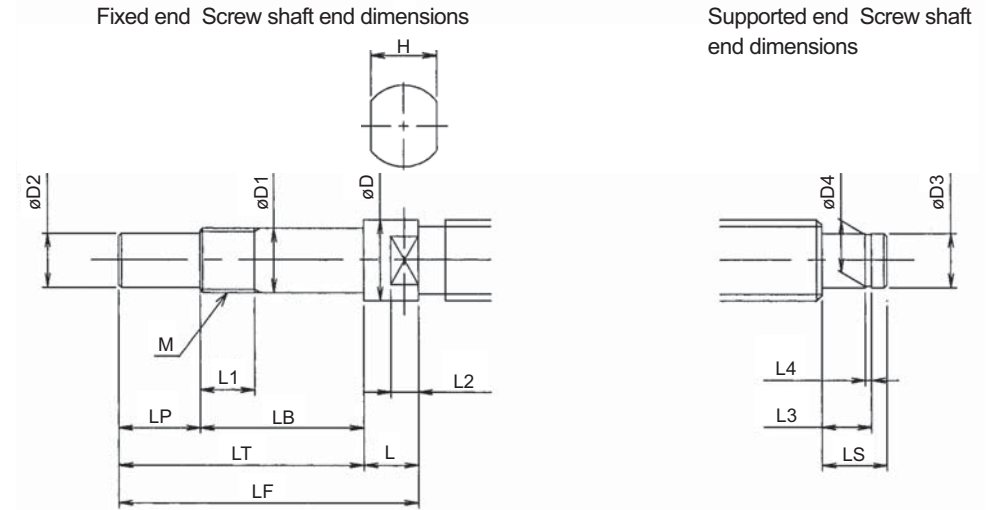

○ Recommended dimensions of screw shaft ends for Square type: BUK and Round type: BUM

Model No. (Fixed end)	LP	øD2 (Tolerance)	LB	øD1 (Tolerance)	LT	L	øD	LF	L2	H (Tolerance)	L1	M	Model No. (Supported end)	LS	L3 (Tolerance)	øD3 (Tolerance)	L4 (Tolerance)	øD4 (Tolerance)
BUK-6 BUKE-6 BUM-6	7.5	4.5 0 -0.008	22.5	6 -0.002 -0.007	30	7	9.5	37	3	8 0 -0.2	7	M6 X0.75	-	-	-	-	-	-
BUK-8 BUKE-8 BUM-8	10	6	27	8 -0.002 -0.008	37	8	11.5	45	4	10	9	M8 X1	BUK-6S BUM-6S	9	6.8	6 -0.002 -0.010	0.8 +0.1 0	5.7 0 -0.06
BUK-10 BUKE-10 BUM-10	15	8	30	10	45	10	14	55	5	12	10	M10 X1	BUK-8S BUM-8S	10	7.9	8 -0.004 -0.012	0.9	7.6
BUK-12 BUKE-12 BUM-12	15	10	30	12 -0.003 -0.011	45	10	15	55	5	12 0 -0.25	10	M12 X1	BUK-10S BUM-10S	12	9.15 +0.1 0	10 -0.004 -0.012	1.15	9.6 0 -0.09
BUK-15 BUM-15	20	12	40	15	60	15	20	75	5	17	15	M15 X1	BUK-15S BUM-15S	12	10.15	15 -0.004 -0.012	+0.14 0	14.3 0 -0.11
BUK-20 BUM-20	27	15	53	20 -0.003 -0.012	80	20	25	100	10	22 0 -0.35	16	M20 X1	BUK-20S BUM-20S	18	15.35	20 -0.004 -0.013	1.35	19 0 -0.21
BUK-25 BUM-25	33	20	62	25 -0.005 -0.014	95	27	32	122	12	27	20	M25 X1.5	BUK-25S	20	16.35	25 -0.004 -0.013	23.9	

(Note) Dimensions may differ from those recommended, depending on the type of the unfinished shaft of standard products.

## BUKE series

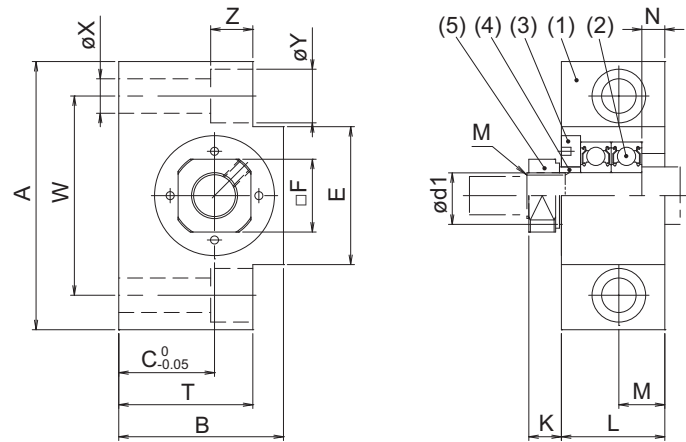

Model No.	ød1	A	B	C	T	E	□F	K	L	R	N
BUKE-6	6	42	25	13	20	18	12	6	20	10	3.5
BUKE-8F	8	52	32	17	26	25	14	7	23	11.5	4
BUKE-10F	10	70	43	25	35	36	17	8.5	27	12	6
BUKE-12F	12	70	43	25	35	36	19	8.5	27	12	6

(Note 1) The above is the net weight and does not include that of the packing material.

### • Dimensions of rolled ball screws collars

Model No.	ød	øDC (Tolerance)	LC
GY/W-C06	6	9.5	7
GY/W-C08	8	11.5	8
GY/W-C10	10	14	10
GY/W-C12	12	15	10

Rolled ball screws collars to be used as bearing shoulders

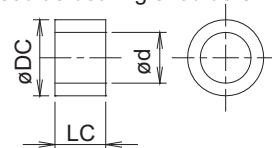

(Note 1) When the above parts are used with the rolled ball screw, a bearing shoulder-functioning collar is required.

(Note 2) The collar is not included in the standard parts of the support unit. When using with rolled ball screws, the optional collar is available on request.

## Support unit for light loads and transfer applications: SQUARE TYPE FIXED END UNIT

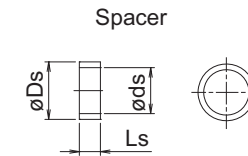

(Unit: mm)

W	øX	øY	Z	M	øds	øDs	Ls	Mass (kg)
30	5.5	9.5	11	M6×0.75	6	9.5	5	0.10
38	6.6	11	11	M8×1	8	11.5	5.5	0.23
52	9	14	11	M10×1	10	14	5.5	0.49
52	9	14	11	M12×1	12	15	5.5	0.50

# BUK series

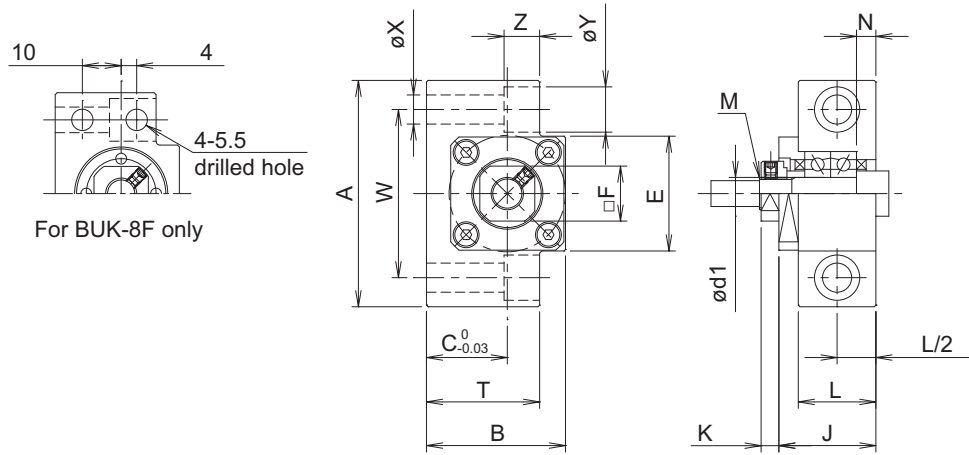

Model No.	ød1	A	B	C	T	E	□F	J	K	L	N
BUK-6	6	42	25	13	20	18	12	20	5.5	20	3.5
BUK-8F	8	52	32	17	26	25	14	23	7	23	4
BUK-10F	10	70	43	25	35	35.5	17	30	5.5	24	6
BUK-12F	12	70	43	25	35	35.5	19	30	5.5	24	6
BUK-15F	15	80	50	30	40	41	22	31	12	25	5
BUK-20F	20	95	58	30	45	56	30	52	10	42	10
BUK-25F	25	105	68	35	25	66	36	61	13	48	14

(Note 1) The above is the net weight and does not include that of the packing material.

## • Dimensions of rolled ball screws collars

Model No.	ød	øDC (Tolerance)	LC
GY/W-C06	6	9.5	7
GY/W-C08	8	11.5	8
GY/W-C10	10	14	10
GY/W-C12	12	15	10
GY/W-C15	15	20	15
GY/W-C20	20	25	20
GY/W-C25	25	32	25

Rolled ball screws collars to be used as bearing shoulders

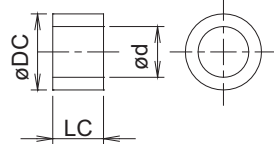

(Note 1) When the above parts are used with the rolled ball screw, a bearing shoulder-functioning collar is required.

(Note 2) The collar is not included in the standard parts of the support unit. When using with rolled ball screws, the optional collar is available on request.

# Support unit for small-sized factory automation equipment: SQUARE TYPE FIXED END UNIT

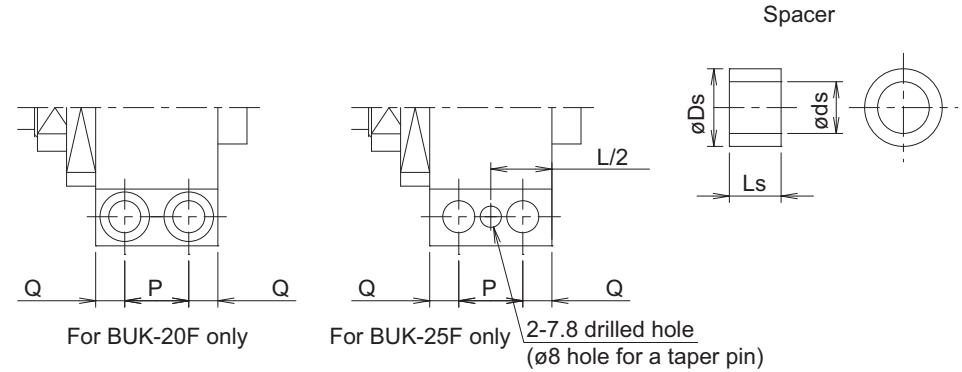

(Unit: mm)

P	Q	W	X	Y	Z	M	øds	øDs	Ls	Mass (kg)
-	-	30	5.5	9.5	11	M6×0.75	6	9.5	5	0.10
-	-	38	6.6	11	12	M8×1	8	11.5	5.5	0.23
-	-	52	9	14	11	M10×1	10	14	5.5	0.49
-	-	52	9	14	11	M12×1	12	15	5.5	0.50
-	-	60	11	17	15	M15×1	15	20	10	0.65
22	10	75	11	17	15	M20×1	20	25	11	1.48
30	9	85	11	-	-	M25×1.5	25	31	14	1.90

## BUK series

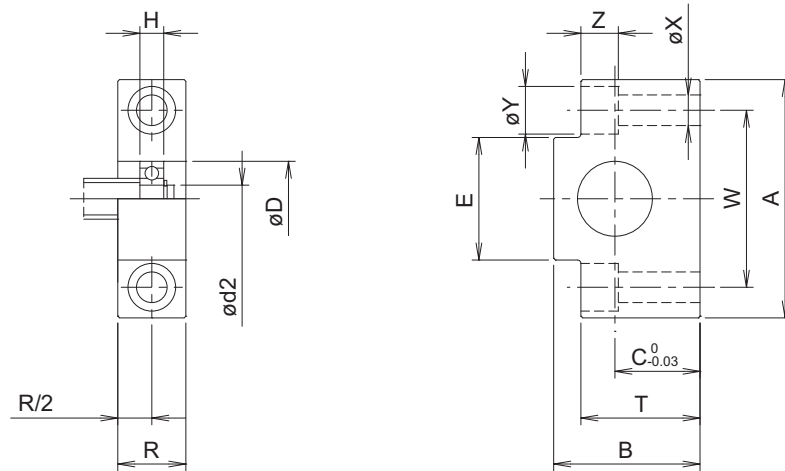

Model No.	ød2	øD	H	R	A	B	C	T	E	W	X
BUK-6S	6	17	6	15	52	32	17	26	25	38	6.6
BUK-8S	8	22	7	20	70	43	25	35	35.5	52	9
BUK-10S	10	26	8	20	70	43	25	35	35.5	52	9
BUK-15S	15	32	9	20	80	50	30	40	41	60	11
BUK-20S	20	47	14	26	95	58	30	45	56	75	11
BUK-25S	25	52	15	30	105	68	35	25	66	85	11

(Note 1) The above is the net weight and does not include that of the packing material.

## Support unit for small-sized factory automation equipment: SQUARE TYPE SUPPORTED END UNIT

(Unit: mm)

Y	Z	Snap ring	Mass (kg)
11	12	Nominal 6	0.17
14	11	Nominal 8	0.37
14	11	Nominal 10	0.36
17	15	Nominal 15	0.46
17	15	Nominal 20	0.76
-	-	Nominal 25	0.98

### • Part numbers for matched pairs

Model No.	Model No.
BUK-6	---
BUK-8F	BUK-6S
BUK-10F	BUK-8S
BUK-12F	BUK-10S
BUK-15F	BUK-15S
BUK-20F	BUK-20S
BUK-25F	BUK-25S

## BUM series

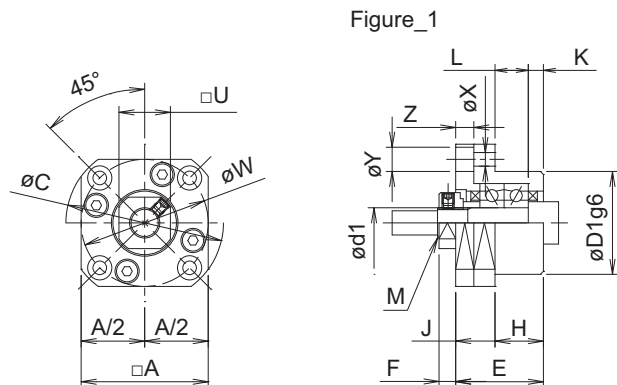

Model No.	$\phi d1$	$\square A$	$\phi C$	$\phi D1$	E	F	H	J	K	L	N
BUM-6F	6	28	35	22	20	5.5	13	7	3.5	9.5	6.5
BUM-8F	8	35	43	28	23	7	14	9	4	10	8
BUM-10F	10	42	52	34	29	5.5	16	13	5	11	8.5
BUM-12F	12	44	54	36	29	5.5	16	13	5	11	8.5
BUM-15F	15	52	63	40	32	12	17	15	6	11	14
BUM-20F	20	68	85	57	52	10	30	22	10	20	14
BUM-25	25	79	98	63	57	13	30	27	10	20	20

(Note 1) The above is the net weight and does not include that of the packing material.

### • Dimensions of rolled ball screws collars

Model No.	$\phi d$	$\phi DC$ (Tolerance)	LC
GY/W-C06	6	9.5	7
GY/W-C08	8	11.5	8
GY/W-C10	10	14	10
GY/W-C12	12	15	10
GY/W-C15	15	20	15
GY/W-C20	20	25	20
GY/W-C25	25	32	25

Rolled ball screws collars to be used as bearing shoulders

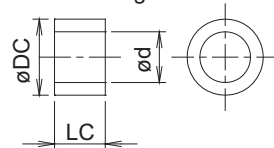

(Note 1) When the above parts are used with the rolled ball screw, a bearing shoulder-functioning collar is required.

(Note 2) The collar is not included in the standard parts of the support unit. When using with rolled ball screws, the optional collar is available on request.

## Support unit for small-sized factory automation equipment: ROUND TYPE FIXED END UNIT

Figure\_2

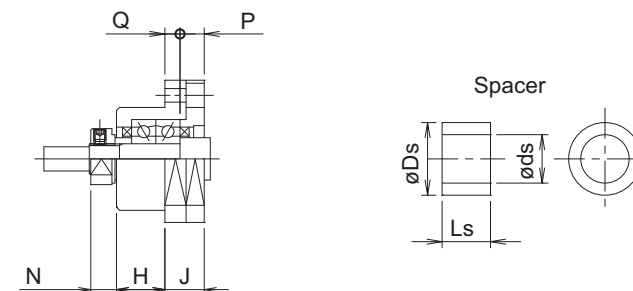

(Unit: mm)

P	Q	$\square U$	$\phi W$	X	Y	Z	M	$\phi ds$	$\phi Ds$	Ls	Mass (kg)
4.5	2.5	12	28	2.9	5.5	3.5	M6×0.75	6	9.5	5	0.08
5	4	14	35	3.4	6.5	4	M8×1	8	11.5	5.5	0.18
8	5	17	42	4.5	8	6	M10×1	10	14	5.5	0.24
8	5	19	44	4.5	8	6	M12×1	12	15	5.5	0.26
8	7	22	50	5.5	9.5	6	M15×1	15	20	10	0.40
14	8	30	70	6.6	11	10	M20×1	20	25	11	1.09
17	10	36	80	9	15	13	M25×1.5	25	31	14	1.51

# BUM series

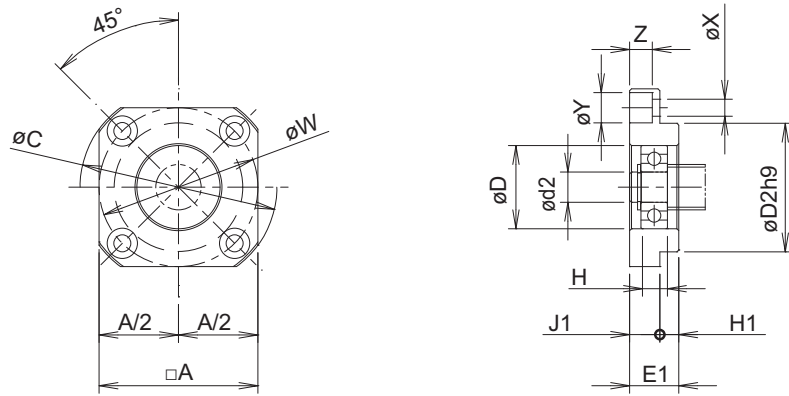

Model No.	ød2	øD	H	□A	øC	øD2	E1	J1	H1	øW	X
BUM-6S	6	17	6	35	43	28	10	6	4	35	3.4
BUM-8S	8	22	7	42	52	34	13	8	5	42	4.5
BUM-10S	10	26	8	44	54	36	15	7	8	44	4.5
BUM-15S	15	32	9	52	63	40	17	9	8	50	5.5
BUM-20S	20	47	14	68	85	57	20	11	9	70	6.6

(Note 1) The above is the net weight and does not include that of the packing material.

# Support unit for small-sized factory automation equipment: ROUND TYPE SUPPORTED END UNIT

(Unit: mm)

Y	Z	Snap ring	Mass (kg)
6.5	4	Nominal 6	0.06
8	6	Nominal 8	0.11
8	6	Nominal 10	0.12
9.5	6	Nominal 15	0.17
11	10	Nominal 20	0.38

## Part numbers for matched pairs

Model No.	Model No.
BUM-6F	---
BUM-8F	BUM-6S
BUM-10F	BUM-8S
BUM-12F	BUM-10S
BUM-15F	BUM-15S
BUM-20F	BUM-20S
BUM-25F	---

## BUK series

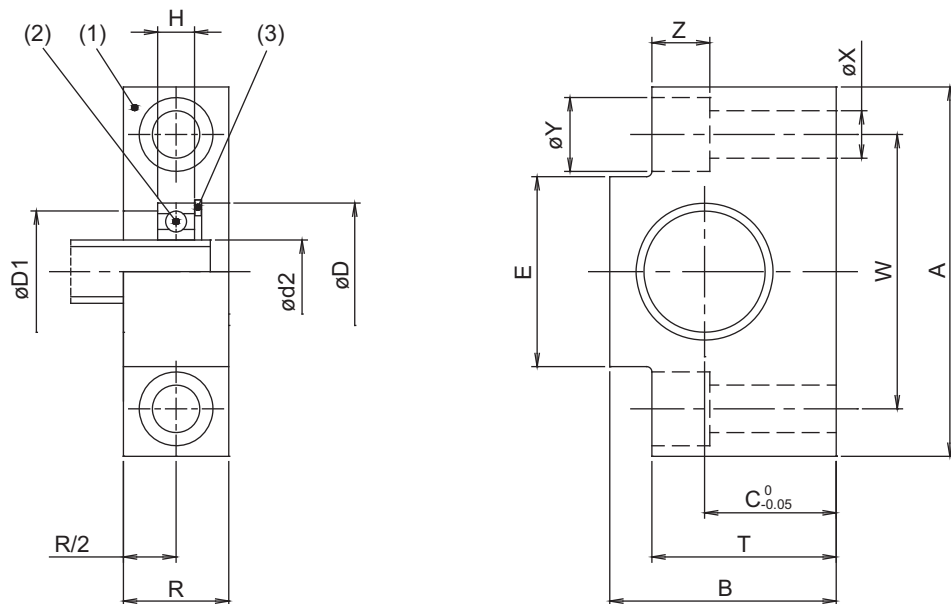

Model No.	ød2	øD	øD1	H	R	A	B	C	T	E	W
BUK-12T	12	28	24	8	20	70	43	25	35	35.5	52
BUK-15T	15	28	24	7	20	70	43	25	35	35.5	52

(Note 1) The above is the net weight and does not include that of the packing material.

## Support Unit for Small-sized Factory Automation Equipment: SQUARE TYPE SUPPORTED END UNIT

### • Main parts and materials

No.	Description	Material	Q'ty	Remark
1	Bearing housing	Structural steel	1	Blackening
2	Bearing		1	
3	Clip washer		1	10

### • Bearing specifications (deep groove ball bearing)

Model No. of support unit	Model No. of bearing	Basic dynamic load rating (N)
BUK-12T	6001ZZ	5100
BUK-15T	6902ZZ	4350

(Unit: mm)

X	Y	Z	Snap ring	Mass (kg)
9	14	11	Nominal 28	0.32
9	14	11	Nominal 28	0.31



## BUT series

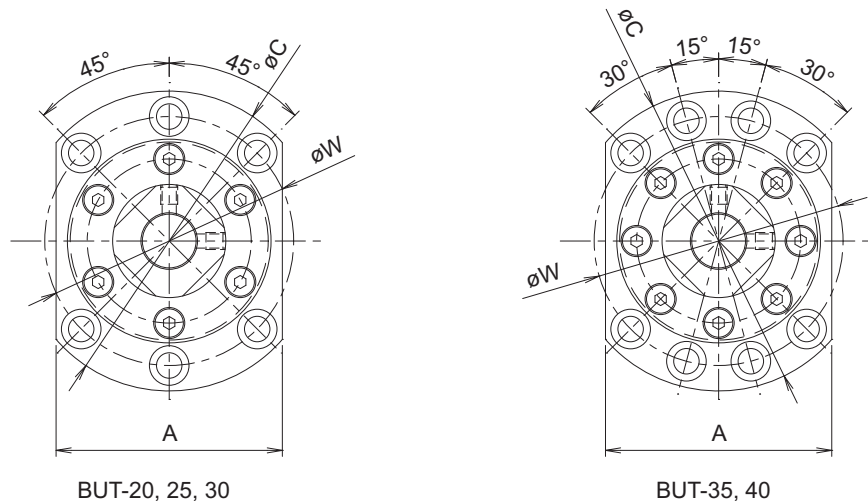

## Support unit for machine tools: ROUND TYPE FIXED END UNIT

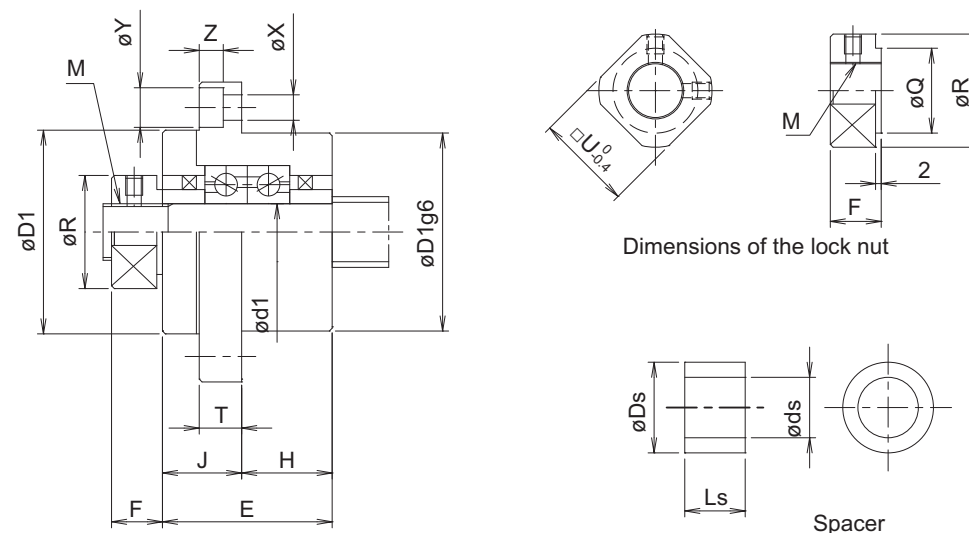

Dimensions of the lock nut

Spacer

(Unit: mm)

Model No.	ød1	A	øC	øD1	E	F	H	J	T	øR	U
BUT-20	20	80	106	70	60	18	32	28	15	40	32
BUT-25	25	100	130	85	66	20	33	33	18	45	36
BUT-30	30	100	130	85	66	20	33	33	18	50	41
BUT-35	35	106	142	95	66	25	33	33	18	55	46
BUT-40	40	106	142	95	66	25	33	33	18	60	50

(Note 1) The above is the net weight and does not include that of the packing material.

øQ	øW	øX	øY	Z	M	øds	øDs	Ls	Mass (kg)
30	88	9	14	8.5	M20×1	20	30	15	2.0
40	110	11	17.5	11	M25×1.5	25	40	18	3.4
40	110	11	17.5	11	M30×1.5	30	40	18	3.3
50	121	11	17.5	11	M35×1.5	35	50	18	3.9
50	121	11	17.5	11	M40×1.5	40	50	18	3.8

### • BUT (round type) Dimensions of the fixed shaft end for bearing mounting (for reference)

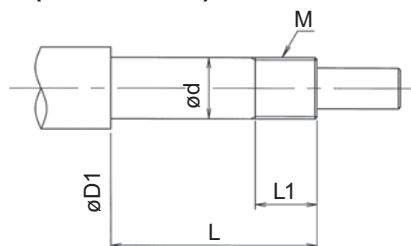

Model No.	Dimensions of the fixed shaft end for bearing mounting				
	øD1	ød1	L	L1	M
BUT-20	30	20 <sup>-0.003</sup> <sub>-0.012</sub>	81	23	M20×1
BUT-25	40	25 <sup>-0.003</sup> <sub>-0.012</sub>	89	25	M25×1.5
BUT-30	40	30 <sup>-0.003</sup> <sub>-0.012</sub>	89	25	M30×1.5
BUT-35	50	35 <sup>-0.004</sup> <sub>-0.015</sub>	94	30	M35×1.5
BUT-40	50	40 <sup>-0.004</sup> <sub>-0.015</sub>	94	30	M40×1.5

## How to assemble the square type support unit

### Support unit assembly

- 1) Fit the support unit to the ball screw.
  - Do not disassemble the bearing unit.
  - Exercise care to prevent the oil seal from peeling off.
  - When tightening the lock nut, be sure of the runout of the shaft end.
- 2) Slip the support bearing on the shaft and fix it in place with a snap ring.

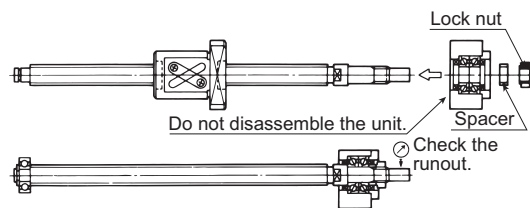

### Support unit assembly

- 1) Lightly tighten the ball screw nut to the housing.
- 2) Lightly tighten the support unit to the frame. Move the table to the supported side and adjust the alignment of ball screw shaft to match the center of the bearing to achieve optimal movement:
  - (1) Adjust the position of the square type support unit with an appropriate shim to match the nut housing.
  - (2) Using the nut housing as a reference point, adjust to have a gap between the round type support unit and the frame.
  - (3) Adjust the position of the nut housing with an appropriate shim to match the square type or round type support unit.
  - (4) Using the support unit as a reference point, adjust to have a gap between the square type or round type support unit and the nut housing.

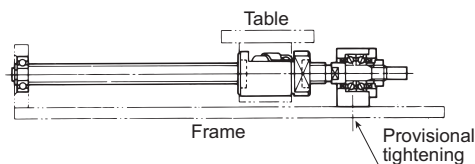

### Be sure of that the supported end bearing is assembled correctly

- 1) Move the table to the supported end and center the ball screw. Lightly tighten the supported end bearing housing to the frame.
  - (1) Check the runout.
  - (2) Check the torque.
- 2) While moving the table back and forth, adjust to achieve smooth movement.
- 3) Tighten and fix the bearing housing while checking the alignment and runout of each part.

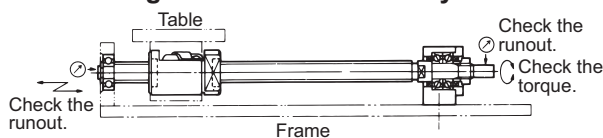

### Assemble the ball screw shaft to the motor with a coupling

- 1) Assemble the motor bracket to the frame with proper positioning.
- 2) Join the motor and the ball screw with a coupling.
- 3) After assembly has been completed, manually run the actuator a few times back and forth to eliminate remaining misalignment.

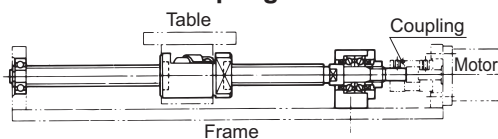

## How to assemble the round type support unit

### Fit the support unit to the ball screw

When the bearing lock nut is fixed with a spanner, the lock nut may shift in the direction of the indicated arrow due to the gap between the external thread and internal thread. This may cause misalignment and bending of the screw shaft.

Both poor alignment and operating a bent shaft may result in the reduction of feed accuracy and the shortening of service life. In addition, it may cause abnormal sounds, vibration, and other problems such as broken screw shafts.



### Things to note when tightening the bearing lock nut

- (1) Lightly tighten the bearing lock nut.
- (2) Support the screw shaft with a V-block, engage a dial gauge at A or B (shown in the illustration to the right) and find a position at which the deflection of the pointer is maximized while turning the screw shaft.
- (3) Using a hammer as shown in the illustration, lightly tap the bearing lock nut at the above-mentioned backlash alignment position to reduce the deflection of the pointer.

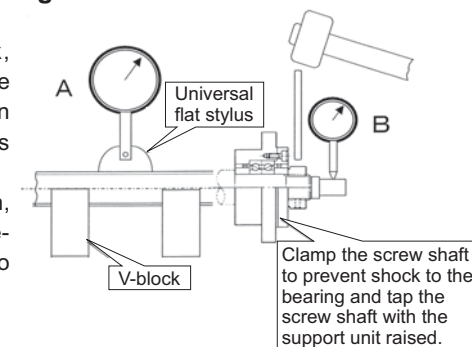

### Tighten the bearing lock nut after fixing the support unit to the machine table

- (1) Set a dial gauge vertically and horizontally.
- (2) Lightly tighten the bearing lock nut.
- (3) As shown in the illustration, lightly tap the bearing lock nut with a hammer to reduce the deflection of the pointer. If the pointer of the dial gauge does not deflect when the bearing lock nut is lightly tap, loosen the lock nut and repeat the process to prevent shock to the bearing.

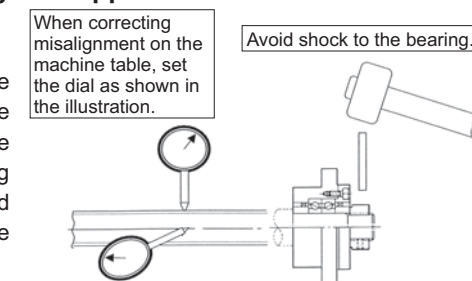

\* For the recommended tightening torque, consult KURODA.